



THE
COLLEGE
OF THE
FLORIDA KEYS

SALARY SCHEDULE 2022-2023



Contents

INTRODUCTION	5
OBJECTIVES	5
ACCREDITATION	5
NON-DISCRIMINATION STATEMENT	5
WEBSITE	5
GENERAL PROVISIONS	6
EFFECTIVE DATE	6
ELIGIBILITY	6
SALARY COMPUTATION	6
SALARY INCREASES	6
ADDITION OF POSITIONS AND JOB CLASSIFICATIONS	6
MAXIMUM OF SALARY RANGE	6
PRESIDENT’S AUTHORITY	7
NON-FACULTY EMPLOYMENT FOR LESS THAN 12 MONTHS	7
INTERIM POSITIONS	7
GRANT-FUNDED POSITIONS	7
EMPLOYEE EVALUATIONS	7
SALARY INCREASE METHODS	7
RECORD KEEPING	8
STARTING SALARY DETERMINATION	8
INITIAL SALARY PLACEMENT	8
EDUCATION ON THE JOB	9
PROMOTION	9
DEMOTION	9
RECLASSIFICATION / ORGANIZATIONAL CHANGES	9
TRANSFER	9
UPGRADE	10
TEMPORARY ASSIGNMENTS	10
WORK WEEK	10
VOLUNTEERS	11
EXECUTIVE, ADMINISTRATIVE, AND PROFESSIONAL	13
EXEMPT STATUS	13
PART-TIME PROFESSIONAL POSITIONS	13
MONTHLY, ANNUAL, AND MULTI-YEAR CONTRACTS	13

EMPLOYEE EVALUATIONS	13
INSTRUCTIONAL SUPPLEMENTS.....	14
REPORTING REQUIREMENTS	14
FACULTY	18
STARTING SALARY DETERMINATION.....	18
STARTING SALARY - EXPERIENCE FACTORS GUIDELINES	18
CONTRACT LENGTHS FOR INSTRUCTIONAL FACULTY	19
LEVEL PLACEMENT.....	19
CREDENTIALING CRITERIA.....	19
FACULTY EVALUATIONS.....	20
EDUCATION ON THE JOB.....	20
FACULTY 2022-2023 SALARY SCHEDULE.....	21
FACULTY DUTY DAY	21
INSTRUCTIONAL LOAD CREDIT.....	21
OVERLOAD CREDIT	22
SUMMER TERM COMPENSATION FOR FULL-TIME FACULTY	22
SUBSTITUTE COMPENSATION	23
NON-CREDIT COMPENSATION.....	23
TRAVEL-TIME COMPENSATION FOR INSTRUCTION AT TEMPORARY OFF-SITE LOCATION	23
INDEPENDENT STUDY	24
ONLINE LEARNING COURSE INSTRUCTION.....	25
ONLINE COURSE DEVELOPMENT COMPENSATION	25
RELEASE TIME	25
FACULTY TITLES.....	25
ADJUNCT AND OVERLOAD COMPENSATION	28
ADJUNCT PERFORMANCE EVALUATIONS.....	28
SENIOR ADJUNCT FACULTY	28
PROFESSIONAL DUTY COMPENSATION.....	28
CAREER.....	30
EMPLOYMENT AUTHORIZATION.....	30
NON-EXEMPT STATUS, OVERTIME ELIGIBILITY	30
PART-TIME CAREER POSITIONS.....	30
EMPLOYEE EVALUATIONS	30
CAREER 2022-2023 SALARY SCHEDULE.....	32
MISCELLANEOUS EMPLOYMENT	34
EMPLOYMENT OF DAY LABOR AND PERSONNEL SERVICE CONTRACTS	34

OTHER EMPLOYMENT	34
SUPPLEMENTAL PAY FOR STUDENT CLUB ADVISORS.....	34
EMPLOYEE CATEGORIES AND COLLEGE-PAID FRINGE BENEFITS.....	36
EMPLOYEE CATEGORIES	36
ELIGIBILITY FOR FRINGE BENEFITS PAID BY THE COLLEGE BASED ON EMPLOYEE CATEGORY.....	36
APPENDIX A.....	37
ORGANIZATIONAL CHARTS.....	37

INTRODUCTION

The College of the Florida Keys Salary Schedule is established annually pursuant to State Board of Education Rule 6A-14.0261, Florida Statute 1001.64(18) and College Board Rule 5.210. The President recommends the Salary Schedule to the Board of Trustees at the June Board Meeting. Once adopted, the Salary Schedule becomes the sole instrument used to determine employee compensation. Personnel records of the College contain evidence of the methods used in calculating compensation for employees.

OBJECTIVES

This Salary Schedule is designed to meet the following objectives:

1. Comply with State and Federal compensation regulations.
2. Utilize available resources to meet College goals within a framework of equitable compensation practices.
3. Ensure fair treatment of employees through internal consistency.
4. Enhance the ability to attract and retain qualified faculty and staff.
5. Provide a clear and concise reference for fair compensation decisions.

ACCREDITATION

The College of the Florida Keys is accredited by the Southern Association of Colleges and Schools Commission on Colleges (SACSCOC) to award associate and baccalaureate degrees. Questions about the accreditation of The College of the Florida Keys may be directed in writing to the Southern Association of Colleges and Schools Commission on Colleges at 1866 Southern Lane, Decatur, Georgia 30033-4097, by calling (404) 679-4500, or by using information available on the SACSCOC's website (www.sacscoc.org).

NON-DISCRIMINATION STATEMENT

The College of the Florida Keys does not discriminate on the basis of race, color, national origin, ethnicity, age, sex (including sexual orientation and gender identity), marital status, military status, protected veteran status, genetic information, religion, pregnancy, or disability in its programs, activities, or employment practices. The following persons have been designated to handle inquiries and grievances regarding the non-discrimination policies:

Equity Officer: Jose Reyes, Assistant Director, Talent Acquisition, Development, and Accountability (305) 809-3163 or jose.reyes1@cfk.edu

Title IX Coordinator: Naomi Walsh, Assistant to the Vice President, Advancement (305) 809-3198 or naomi.walsh@cfk.edu

Disability Services: Katie Norland, Director, Student Success Services (305)809-3181 or katie.norland@cfk.edu

WEBSITE

This salary schedule may be viewed online at www.cfk.edu.

GENERAL PROVISIONS

EFFECTIVE DATE

The 2022-2023 Salary Schedule is effective July 1, 2022, through June 30, 2023.

ELIGIBILITY

Pursuant to College Board Rule 5.621: Criteria for employment at the College includes, but is not limited to, educational requirements, prior experience, knowledge related to specific position, and commitment to the mission and vision of the College.

Prior to approval by the Board of Trustees the following will be completed:

- Professional Reference Checks
- Driver's License Check, if applicable

Within 30 days of employment, a Criminal History Investigation (which includes fingerprinting and a national search) must be completed by the employee.

SALARY COMPUTATION

Salary computation for exempt positions such as Faculty, Executives, Administrators, and Professionals is annualized and rounded up to the nearest dollar. Salary computation for non-exempt positions, such as Career employees, is based on hourly rate.

SALARY INCREASES

Annual salary increases may be recommended to the Board of Trustees and are dependent upon the availability of funding and other revenues. There are no guaranteed salary increases for any position or classification of positions. Employees are eligible:

If employed as of July 1 of the previous year, or if employed in regular positions that run from one academic year to the next academic year.

An annual salary increase may be given as a one-time lump sum payment or added to the employee's base salary. A salary increase given as a one-time lump sum payment is not eligible for payout calculation if the employee should leave the College and is not eligible for Florida Retirement System contributions.

Employees who are in a probationary status, regular part-time and temporary employees are subject to wage increases only under special circumstances. Employees who terminate or resign prior to the first pay period of the fiscal year will not be considered eligible for an annual increase.

ADDITION OF POSITIONS AND JOB CLASSIFICATIONS

Additional job titles, job descriptions and classifications may be developed as needed based upon the recommendation of a Vice President and Office of Talent Acquisition, Development, and Accountability (TADA), with the approval of the President. It is not necessary for the Board to approve new job descriptions. The TADA Office maintains job descriptions.

MAXIMUM OF SALARY RANGE

When an employee reaches the maximum in a salary range, only a non-recurring adjustment will be paid as a lump

sum when approved by the Board of Trustees. This type of adjustment is not added to the employee's base salary. Supplemental payments and payments for instruction, when not part of regular duties, are in addition to regular earnings, and may allow an employee to exceed their assigned salary range.

PRESIDENT'S AUTHORITY

The President is authorized to hire and to terminate contractual and non-contractual employees. The hiring of part-time employees is authorized by the President or designee. New hire recommendations, employee terminations, and adjustments to pay are brought to the Board of Trustees for approval.

NON-FACULTY EMPLOYMENT FOR LESS THAN 12 MONTHS

A full-time, non-faculty employee may be hired in a regular position on a contractual basis for a period of less than 12-months, subject to the President's approval. These employees are eligible for all benefits available to 12-month employees, with leave prorated.

INTERIM POSITIONS

A person may be appointed to an interim position by the President and approved by the Board of Trustees, as necessary. Interim assignments may not last longer than two years.

GRANT-FUNDED POSITIONS

When a new position is grant-funded, a job description is developed by the supervisor and the Office of TADA. Based on the duties, TADA places the position at the appropriate classification on the Salary Schedule; the salary may be specified by the grant. College funding beyond the grant period is determined by business necessity and other factors. Employees holding a grant-funded position are required to record grant-funded hours separately from College-funded hours on timesheets.

EMPLOYEE EVALUATIONS

At a minimum, all full-time employees will be evaluated annually prior to the close of the fiscal year. Employees with performance evaluations indicating a need for improvement are eligible for salary increases only if recommended by the Supervisor and approved by the appropriate Vice President and the President.

SALARY INCREASE METHODS

Across-the-Board

Cost of Living

Promotion/Transfer

Reclassification

Education on the Job

Salary Range Adjustment

Merit Award – should the College adopt a performance plan, additional adjustments may be made for market conditions, pay equity, increased work or related factors determined by the President.

NOTE: For members of the bargaining unit, increases may be subject to negotiation and approval of the union. The bargaining unit includes all full-time instructional personnel as well as select non-instructional personnel. See pages 16 – 17 for identification of non-instructional positions.

RECORD KEEPING

The TADA Office maintains employee compensation documentation for payment and audit purposes.

STARTING SALARY DETERMINATION

Executive, Administrative, Professional, and Career employees, when recommended by the President or designee and approved by the Board of Trustees, are hired at the appropriate employee level and salary range for the position. The hiring rate for employees is the minimum in the salary range plus up to 10%, depending on the extent to which employee qualifications exceed the minimum qualifications for the job. Further, in limited circumstances, an employee salary may be adjusted, if necessary, to reflect pay equity relative to other salaries in that pay level or grade. Also, in limited circumstances, a salary that exceeds this range may be paid to highly qualified candidates to recognize hiring-market conditions, if recommended by the President and approved by the Board of Trustees.

For all levels, copies of transcripts or certificates are required prior to hiring approval and official transcripts are required within 30 days of the hire date. The College recognizes the value of education and experience in employment for new hires using the following guidelines:

INITIAL SALARY PLACEMENT

Employees are initially assigned to a salary within the appropriate level based upon the following criteria:

- 1) Salary is determined by the level of responsibility held by the position and by the years of verifiable experience applicable to the position.
- 2) The minimum salary of the range of the position.
- 3) Two percent (2%) may be granted above the minimum salary for all conferred degrees beyond the minimum required for the position.
- 4) One percent (1%) may be granted above the minimum for each year of relevant work experience beyond the minimum required for the position.
- 5) One percent (1%) may be granted above the minimum for applicable/relevant industry, professional, and technical certifications beyond the minimum required for the position.
- 6) Starting salary is limited to not more than 10% above the minimum, but may be adjusted further, if necessary, for the position.
- 7) A higher salary may be granted for unusual expertise; skill or value to the College; or market demand at the discretion of the President and approved by the Board of Trustees.
- 8) Generally, the educational *and* experience requirements must be met before a percentage increase is awarded above the minimum. Salary may be adjusted further, if necessary, for pay equity or market demand, as determined by the President and approved by the Board of Trustees.

Compensation Procedures for Rehired Employees:

Former employees who have left the service of the College and are rehired into the same pay level within one year of the date they terminated with the College, may receive the same salary in effect when they left, (unless prevented by budget constraints) or receive the minimum salary for the classification plus recognition for education or experience up to 10%.

EDUCATION ON THE JOB

Executive, Administrative, Professional, and Career employees who acquire an additional degree beyond the minimum degree required for their positions from an accredited institution are eligible to receive a salary increase to base pay, detailed in the following table. The salary increase will be effective in the payroll following receipt of the official transcript by the TADA Office, provided funds are available in the departmental budget. (See Faculty Section for Education on the Job for Faculty)

DEGREE RECEIVED	SALARY INCREASE
Doctorate	\$5,000
Master's	\$4,000
Bachelor's	\$3,000
Associate	\$2,000

*Job-related industry, professional, and technical certifications completed on the job may be eligible for a one-time incentive-pay stipend or an increase to base salary as recommended by the Director, TADA and approved by the President.

PROMOTION

Promotion is reassignment to a position of higher skills, responsibility, and salary range. A promotion occurs when a qualified employee is moved from a position in one pay grade to another position which is a higher salary grade or level.

The promoted employee may receive a salary increase to at least the minimum rate of the new pay range up to 10% above the minimum (see "Initial Salary Placement"). The salary may be adjusted for pay equity relative to other salaries in that pay level or grade as determined by the President and approved by the Board of Trustees.

DEMOTION

A demotion occurs when an employee is transferred to a position in a lower grade or level. Whether the demotion is voluntary or involuntary an appropriate salary will be recommended by the President and approved by the Board of Trustees.

RECLASSIFICATION / ORGANIZATIONAL CHANGES

When a position is reclassified to a higher or lower salary level or grade, adjustments to salary may be handled in the same manner as a promotion or demotion. Departmental or institutional reorganizations may be recommended and submitted for consideration during the budget process each year. Exceptions to this rule will only be made by the President and approved by the Board of Trustees.

TRANSFER

Employees transferred to a position in the same classification or to a different position within the same pay range are not eligible for an increase.

UPGRADE

A position upgrade occurs when the duties and responsibilities of the position are substantially changed, and the position is moved to a higher salary grade or level. The employee in the original position prior to the upgrade may or may not move with the position.

TEMPORARY ASSIGNMENTS

Position Assignment to a Higher Level

Employees may be required to assume the duties and responsibilities of a higher-level vacant position on a temporary basis. When assigned to a position in this manner for a period of more than five days, on the sixth day the employee's salary may be determined as though the employee was promoted to the pay level of the higher position. The President may assign a different salary level as appropriate. This temporary assignment will be for a specified period of time, not to exceed twelve months, and requires the approval of the appropriate Vice President and the President. When the temporary assignment is finished, the employee will return to their previous duties at their previous compensation level.

Extra Duty Assignments

Non-instructional employees who assume additional responsibilities/duties within the same level of their current position because of an increase in workload of the department may be assigned supplemental pay. For payment to be awarded, appropriate documentation of projects, responsibilities or duties which go above and beyond the employee's current job description, is required as is the approval by the employee's supervisor, Vice President, and President.

This work is considered extra work to be calculated at the employee's current hourly wage for the hours worked on this assignment. The supervisor determines the appropriate total number of hours the new duties require of the employee and documents such. Requests for compensation for additional duties will not be approved without supporting documentation and reasons for the request.

NOTE: If an employee is non-exempt and the duties require additional hours, which bring the employee beyond 40 hours per week, then the non-exempt employee is entitled to overtime pay.

WORK WEEK

The regular work week is defined as Monday through Sunday. For full-time Executive, Administrative, Professional and Career employees the work schedule is generally detailed as thirty-seven and one-half (37.5) hours per work week. The regular workday for full-time Executive, Administrative, Professional, and Career employees is generally detailed as seven and one-half hours per day, not including (a half-hour) lunch. For full-time Instructional employees the work schedule is generally detailed as thirty-seven and one-half (37.5) hours per work week. The general business hours of the College are 8:30am to 5:00pm.

However, it should be noted that the work schedule estimated for the work week is not to be construed as a maximum amount of time required for any given position. Depending on the circumstances at the College, it is specifically contemplated that full-time employees will be called upon to work more than 37.5 hours per week. The President may authorize a change in employees' schedules as deemed necessary for the efficient operation of the College.

VOLUNTEERS

For liability purposes, volunteers are required to submit a complete packet of application materials including a criminal background check, *prior* to performing services. All paperwork and materials will remain on file in the TADA Office. All volunteers must be recommended by the department supervisor and approved by the appropriate Vice President and the President.

EXECUTIVE,
ADMINISTRATIVE, AND
PROFESSIONAL

EXECUTIVE, ADMINISTRATIVE, AND PROFESSIONAL

EXEMPT STATUS

Executive, Administrative, and Professional positions are exempt from the Fair Labor Standards Act overtime provisions. As such, it is specifically contemplated that full-time Executive, Administrative, and Professional employees will be occasionally called upon to work more than 37.5 hours per week, depending on the circumstances at the College.

PART-TIME PROFESSIONAL POSITIONS

The standard work schedule for part-time Professional employees is up to 25 hours per week. Individual work schedules are determined by the supervisor. Schedules may vary on a week-to-week basis depending on the needs of the department. Under no circumstances are part-time employees authorized to work more than 25 hours in any given work week without the express authorization of their supervisor, the appropriate dean or vice president, and the President.

Part-time Professional positions are placed in the appropriate pay grade for the position at the time of appointment. Appointment of part-time Professionals is recommended by the President and approved by the Board of Trustees. Pay is determined by the grade in which the position has been classified and is typically set at the minimum pay level for the position. Exceptions may be made for education and experience above that of the required qualifications, with the President's approval.

MONTHLY, ANNUAL, AND MULTI-YEAR CONTRACTS

A contract will not create the expectancy of employment beyond the term of the contract. Executive, Administrative, and Professional employees are appointed to annual, 12-month contracts that begin July 1, and end June 30, of each fiscal year. The President may also recommend that Executive, Administrative, and Professional employees be given contracts for one to eleven months, on terms negotiated and approved by the President and the Board of Trustees. The President's contract is negotiated with and approved by the Board of Trustees for a maximum of three years.

EMPLOYEE EVALUATIONS

Probationary Evaluation

Executive, Administrative, and Professional employees are on a probationary period for the first six months of employment. Employment during this period is at-will and may be terminated at any time by the Employee or the College. The immediate supervisor evaluates job performance at the end of this period and recommends: 1) removal from probation and continuation of employment 2) extension of the probationary period up to an additional three months; or 3) termination of employment. The probationary period may not extend beyond a period of nine months.

Employees who are promoted or transferred to another position are not subject to additional probationary review. However, it is expected that supervisors will monitor job performance and communicate regularly with employees regarding performance and expectations.

Annual Evaluation

Executive, Administrative, and Professional employees participate in an annual evaluation with their

immediate supervisor. The supervisor makes contract recommendations for the employee on the evaluation form for approval by the appropriate Vice President and the President. Final approval is determined by the Board of Trustees no later than the June Board meeting.

INSTRUCTIONAL SUPPLEMENTS

Executive, Administrative, and Professional employees who teach courses not included in their job description are paid according to the Adjunct and Overload compensation schedule.

REPORTING REQUIREMENTS

Placement on the Executive, Administrative, and Professional Salary Schedule does not necessarily indicate such positions are reported to the State Board of Education as an Administrative position. Positions are reported as instructed by the State Board of Education.

**EXECUTIVE, ADMINISTRATIVE, and PROFESSIONAL
2022-2023 SALARY SCHEDULE**

<u>LEVEL</u>	<u>POSITION TITLE</u>	<u>ANNUAL SALARY RANGE**</u>
EXECUTIVE LEVEL J	President	Board of Trustees Negotiated
LEVEL I	Executive Vice President & CFO Vice President, Academic Affairs Vice President, Advancement, Enrollment Management and Executive Director FKEF	\$86,726-\$144,598
ADMINISTRATIVE LEVEL H	Dean, Arts and Hospitality Dean, Marine Science and Technology Dean, Sciences and Nursing Chief Science and Research Officer CFK Academy Principal	\$77,412-\$129,021
LEVEL G	Controller Director, Facilities Director, Talent Acquisition, Development, and Accountability Executive Director, Marketing and Public Relations	\$73,242-\$117,187
PROFESSIONAL LEVEL F	Associate Dean, Enrollment Management Director, Financial Aid Director, Sponsored Programs	\$69,072-\$115,120
LEVEL E	Director, Academic Advising Services Director, Arts and Hospitality Director, Community Engagement and Testing Director, Emergency Medical Services Director, Institute for Public Safety Director, Learning Resource Center Director, Marine Sciences and Technology Director, President's Office Director, Office of the EVP and CFO Director, Sciences and Nursing Director, Student Success Services Senior Application Support Specialist	\$61,630-\$102,719
LEVEL D	Academic Services Advisors* Artist-in-Residence Director, Career Center Manager, Business Office Manager, Enrollment Management Manager, Maintenance Operations	\$54,991-\$91,651

Manager, Purchasing

LEVEL C	Assistant Director, Community Engagement and Testing Assistant Director, Financial Aid Assistant Director, Institute for Public Safety Assistant Director, Learning Resource Center* Assistant Director, Student Resources and Support (UKC)* Assistant Director, Student Success Services* Assistant Director, Talent Acquisition, Development, and Accountability Director, Recruitment Director, Student Activities	\$49,066-\$81,451
---------	--	-------------------

LEVEL B	Assistant to the Vice President, Academic Affairs Assistant to the Vice President, Advancement Business Consultant Coordinator, Developmental Education Program Director, Aquatics	\$43,780-\$72,968
---------	--	-------------------

LEVEL A	Academic Coordinator, Arts and Hospitality Academic Coordinator, Marine Science and Technology Academic Coordinator, Sciences and Nursing Accounting Analyst Career Advisor Coordinator, Apprenticeship Programs Coordinator, Apprenticeship Program Recruitment Coordinator, Certified Nursing Assistant (PT) Coordinator, Enrollment Management Coordinator, Financial Aid and Veterans' Affairs Coordinator, Financial Aid Coordinator, Institute for Public Safety Coordinator, Marketing and Public Relations Coordinator, Recruitment and Scholarships Coordinator, Student Support Services Coordinator, Student Success Services Coordinator, Talent Acquisition, Development, and Accountability Grants Accountant Placement Coordinator	\$39,064-\$65,106
---------	---	-------------------

*This position is included in the Bargaining Unit.

**Salary Range does not reflect the available starting salaries, which are limited to 10.0% above the minimum salary, as per the Starting Salary Determination in this Salary Schedule. Salary Ranges may be adjusted further to reflect pay equity, or market demands, contingent upon budget constraints with the approval of the Director of Talent Acquisition, Development, and Accountability and the President.

FACULTY

FACULTY

STARTING SALARY DETERMINATION

The minimum of each instructional salary range is set by level of education and is the base salary amount for faculty meeting the degree level. Related experience and educational qualifications beyond the minimum increases faculty's starting salary to a maximum of 10% above the minimum salary. Generally, the educational and experience requirements must be met before a percentage increase is awarded above the minimum and may be adjusted further, if necessary, for pay equity or market demand, as determined by the President and approved by the Board of Trustees.

STARTING SALARY - EXPERIENCE FACTORS GUIDELINES

Each year of full-time post-secondary teaching and experience in field or discipline beyond the job requirement (up to ten years maximum) will increase instructional base salary by one percent (up to ten percent maximum). Increments will be calculated at one percent of the base salary for each allowable year, and may be adjusted, if necessary, for pay equity relative to other salaries in that pay level or grade, and/or for market demand.

Candidates whose expertise is needed in critical or highly specialized areas may be employed at the discretion of the President with additional increments for experience, which will be documented in the employee's personnel file.

Credits, experience, and/or degrees not applicable to instructional assignments may be disregarded in determining placement on the Salary Schedule.

Faculty who do not hold the listed degree for a specific level but hold certifications and/or experience that credentials them to teach at that level will be paid at the level they are credentialed to teach, with the approval of the Vice President, Academic Affairs and the President.

Nursing Faculty:

Master's degree in Nursing with one or more professional certifications is placed at Level II.

Bachelor's degree in Nursing with one or more professional certifications is placed at Level III.

Bachelor's degree in Nursing with no professional certifications is placed at Level IV.

Placement at all levels is subject to 10% for additional experience, as specified above.

Nursing Instructors teaching clinical courses are paid in a 3:1 ratio
(3 workload credit hours for every 1 credit hour taught).

TYPE OF EXPERIENCE	LENGTH of EXPERIENCE	INCREMENT for EXPERIENCE
Full-time teaching Post-Secondary	1 year	1 %
Full-time teaching Technical Center	1 year	1 %
Full-time teaching Secondary School *	2 years	1 %
Related work experience	2 years	1 %

*One increment for each year of experience may be given for Secondary school teaching in a field of study directly related to the instructor's assignment. Part-time teaching experience will be prorated.

CONTRACT LENGTHS FOR INSTRUCTIONAL FACULTY

Salaries on the Instructional Salary Schedule are based on a 10-month contract (193 days) assigned as follows:

Fall Term/Term I	80 to 84 duty days
Spring Term/Term II	80 to 84 duty days
Summer Term/Term III	29 duty days *

*Summer Term: Faculty members are required to be on-campus for twenty-nine (29) duty days or 203 hours. Faculty members teaching in a summer term must coordinate with the appropriate Dean to schedule summer work hours.

A duty day is defined as a contractual workday. Full-time Instructional contracts consist of a thirty-seven and a half (37.5) hour work schedule, which includes seven and a half (7.5) discretionary hours. Discretionary hour activities include, but are not limited to, lesson planning, grading, representing the College at meetings with partner organizations, and curriculum development. Days worked beyond contract periods must be approved, in advance, in writing, by the appropriate Dean, for payment.

LEVEL PLACEMENT

Initial placement on the Instructional Salary Schedule is based on the highest level the instructor is credentialed to teach. For all levels, copies of transcripts or certificates are required prior to hiring approval and official transcripts are required within 30 days of hire date.

CREDENTIALING CRITERIA

The College of the Florida Keys is accredited by the Southern Association of Colleges and Schools Commission on Colleges (SACSCOC) to award the associate and baccalaureate degree. TADA personnel review transcripts to determine compliance with the College's credentialing guidelines and make credentialing recommendations to the Vice President, Academic Affairs and the President. The final determination on Faculty credentials lies with the Vice President, Academic Affairs or designee.

FACULTY EVALUATIONS

Probationary Evaluation

Faculty members are on a probationary period for the first term/semester of employment. The immediate supervisor evaluates job performance at the end of this period and recommends: 1) removal from probation and continuation of employment; 2) extension of the probationary period up to an additional three months; or 3) termination of employment. The probationary period may not extend beyond a period of one academic term.

Annual Evaluation

Faculty members participate in an annual evaluation, prior to the June Board meeting, with their immediate supervisor. The supervisor makes contract recommendations for the employee on the evaluation form for approval by the Vice President, Academic Affairs and the President. Final approval is determined by the Board of Trustees no later than the June BOT meeting.

EDUCATION ON THE JOB

Faculty members are placed at an upgraded degree level when the requirements for an additional degree, within the discipline for which they are credentialed to teach, are completed, and an official transcript is on file with the TADA Office. When a faculty member completes an additional degree, from an accredited institution, that would qualify for a change in level placement, the base annual salary is increased by the difference between the minimum pay of the original degree level and the minimum pay of the new degree level. The level change may be effective in the payroll following receipt of the official transcript by the TADA Office.

FACULTY 2022-2023 SALARY SCHEDULE*

Education		10-month	
LEVEL	DEGREE	193 Days Minimum	193 Days Maximum
I	Doctorate	\$65,120	\$108,529
II	Master's + 30	\$61,542	\$102,572
III	Master's HighlyTech. ¹	\$58,159	\$96,936
IV	Bachelor's	\$54,962	\$91,608
V	Associate's	\$51,940	\$86,572

¹Instructors who teach highly technical vocational programs requiring a high degree of professional skill and experience in the field.

* Salary Range may be adjusted contingent upon budget constraints. Salary Range does not reflect the available starting salaries, which are limited to 10.0% above the minimum salary, as per the Starting Salary Determination in this Salary Schedule. Salary Ranges may be adjusted further to reflect pay equity, or market demands, contingent upon budget constraints and the approval of the Director of TADA and the President.

FACULTY DUTY DAY

- College recognized holidays and closures are not considered faculty duty days. A duty day for full-time faculty is a contractual workday, defined as work on campus seven and a half hours each day, thirty-seven and a half hours per week (see paragraph regarding summer term). Office hours are scheduled so students have a reasonable opportunity to meet with faculty. Adjustments to approved schedules must be authorized in advance by the appropriate Academic Dean.
- Full-time faculty are required to schedule a minimum of thirty-seven and a half (37.5) hours each workweek. The workweek will comprise ten (10) on-campus office hours, fifteen (15) class-contact hours, seven and a half (7.5) campus hours, and seven and a half (7.5) discretionary hours; hours may be adjusted, as required, with written approval of the appropriate Academic Dean. College business conducted during campus hours or discretionary hours may include, but is not limited to, preparation for classes, meeting and committee participation, grading assignments, etc. Please see the paragraph regarding work hours during the summer term.
- Overload class hours are in addition to the minimum on campus hours required.

Contract Length	REQUIRED Weekly Hours	DESCRIPTION
10 Month	37.5 hours	15 teaching hours* (12.5 in class) + 10 office hours + 7.5 discretionary hours + 7.5 campus hours

*Please note per Florida Statute 1012.82, "a classroom contact hour consists of a regularly scheduled classroom activity of not less than 50 minutes in a course of instruction." At the College, one teaching hour is equivalent to fifty minutes in class. Fifteen teaching hours is equivalent to 12.5 in class hours.

INSTRUCTIONAL LOAD CREDIT

- Full-time faculty members' instructional load per fall and spring term is five classes, without laboratories, of three

credit hours each, or 15 credit hours in total. For each class taught with less than three credit hours, the full instructional load per term will be 15 credit hours, or as close to 15 credit hours as possible. 10-month faculty members are required to teach 6 credits in the summer term. Please see chart below for additional information regarding the summer schedule.

Contract Length	REQUIRED Total Summer Hours	DESCRIPTION
10 Month	203 hours	90 teaching hours* (75 in class hours) + 60 office hours + 23 discretionary hours + 45 on-campus hours

*Please note per Florida Statute 1012.82, "a classroom contact hour consists of a regularly scheduled classroom activity of not less than 50 minutes in a course of instruction." At the College, one teaching hour is equivalent to fifty minutes in class. Thus, 90 teaching hours is equivalent to 75 in class hours. 10-month contracts include one holiday.

- B. In the event that full-time faculty does not meet the required instructional load, the Vice President, Academic Affairs may approve one of the following to complete the faculty's full load assignment:
- Assignment of an additional course.
 - Development of an online course.
 - Assignment to teach an online course.
 - "Banking" of the deficient load by adding an additional course in the subsequent term.
 - Other assignments, i.e., conducting a faculty or staff workshop, conducting student review workshops, teaching in Continuing Education, tutoring, completing institutional research, recruiting, handbook revisions, etc. The faculty supervisor will establish an outcomes contract reflecting time and contact hours equivalent to a 3-credit course and evaluate the assignment at the end of the term.

Supporting documentation of augmented duties will be included with the Faculty Load Letter.

- C. For combined courses (C) and laboratory courses (L), the credit hours assigned to classroom hours are considered separately from the credit hours assigned to laboratories. For example, one hour load credit is given for one credit hour of class taught. One hour of load credit is given for every two hours of laboratory, unless special conditions allow for a different ratio. The President or designee may approve deviation from this ratio.
- D. When two or more courses are cross listed by the same instructor, these classes are considered one class for instructional salary purposes.
- E. Independent study is not part of assigned instructional load credit for computing salary.

OVERLOAD CREDIT

When courses assigned to a full-time instructor for either Term I or Term II exceed 15 credit hours the excess load credit is considered an overload. Overload compensation will be calculated on additional credit hours taught beyond the standard 15 credit hour load. Payment is made according to the Overload rate outlined in the Adjunct and Overload Compensation section, and is limited to two courses per faculty member, at the discretion of the Vice President, Academic Affairs. In unusual circumstances, when the College finds it necessary, the Vice President, Academic Affairs may approve a deviation from the two-course overload limit. Deviations require approval of the President.

SUMMER TERM COMPENSATION FOR FULL-TIME FACULTY

Faculty are required to teach six credits during Term III (Summer), in addition to assigned administrative duties, as part of their regular load and are paid at the adjunct rate for overload, based on education level.

SUBSTITUTE COMPENSATION

Full-time faculty is not typically authorized to substitute teach during regularly scheduled work hours. If substitute instruction is needed during the faculty's regularly scheduled work hours, the faculty's class, campus and/or office hours are rearranged with the approval of the appropriate Academic Dean.

NON-CREDIT COMPENSATION

Community Education, Recreation & Leisure, Criminal Justice, Nursing

A. Per Classroom Contact Hour:

Recreation and Leisure:	\$15.00 / hour for instructors.
Enrichment & Lifelong Learning:	\$28.00 / hour for instructors.
Technical/Professional/ Community Ed:	\$35.00 / hour for instructors.
Criminal Justice:	\$25.00 / hour for regular instructors and \$28.00 / hour for instructors of advanced and specialized training.
Nursing:	\$30.00 /hour for instructors and \$32. 00 / hour for instructors of advanced and specialized training.

- In cases where an instructor teaches more than 180 hours per term (four - 45hr courses) an additional \$5 per hour may be given with the approval of the President.
- \$25.00/hour for part-time Criminal Justice Instructional Coordinator \$50.00/hour for instructors teaching highly specialized and/or critical and/or hard to hire non-credit courses, with the approval of the President.

B. When highly specialized and/or critical and/or hard to hire non-credit courses are taught, a rate above each specified level may be paid to qualified personnel with the approval of the President.

TRAVEL-TIME COMPENSATION FOR INSTRUCTION AT TEMPORARY OFF-SITE LOCATION

- A. All travel-time compensation must be requested and approved in writing by the Vice President, Academic Affairs or designee prior to the first day of class for which the compensation is requested.
- B. Compensation applies to full-time faculty and adjuncts teaching credit and non-credit courses.
- C. Compensation is paid for teaching at an off-campus temporary location which is: 1) greater than 30 minutes driving time (one way) from official employment site or 2) greater than 30 minutes driving time (one-way) from home. Driving time is computed using an average speed of 45 mph at \$8.10 per hour.
- D. Mileage is paid at the Board approved mileage rate from center to center, or the distance from the instructor's home to the teaching center (whichever amount is less). There is no per diem for meals and lodging.

IF OFFICIAL EMPLOYMENT SITE IS KEY WEST:

Destination	Mileage	One way	Return trip travel time	Compensation
Middle Keys Center	45 miles	1 hour	1 hour	2 hours X 15 meetings = 30 hours 30 hours @ \$8.10 = \$243.00
Upper Keys Center	102 miles	2.25 hours	2.25 hours	4.5 hours X 15 meetings = 67.5 hours 67.5 hours @ \$8.10 = \$546.75

- A. Compensation does not apply to travel to an instructional site outside of Monroe County.
- B. Compensation is not paid for an instructor commuting between place of residence and the official employment site as part of regular teaching load.
- C. This policy applies to regularly scheduled classes meeting a specified number of times at an approved location. It does not apply to field trips.
- D. Compensation is paid at the completion of the scheduled class.

INDEPENDENT STUDY

Requests for independent studies are reviewed on a case-by-case basis by the Vice President, Academic Affairs. Independent Study is given in those exceptional cases when a student needs a required class to fulfill a requirement. Compensation for independent studies for full-time and adjunct faculty members shall be the greater of \$100 or as detailed on the following tables.

Level I: Doctorate Level							
		Rate:		\$642			
Compensation = Rate [1/7 (No. of Credits x No. of Students)]							
Credits	1 Student	2 Students	3 Students	4 Students	5 Students	6 Students	7 Students
1	\$100	\$183	\$275	\$367	\$458	\$550	\$642
2	\$183	\$367	\$550	\$733	\$917	\$1,100	\$1,283
3	\$275	\$550	\$825	\$1,100	\$1,375	\$1,650	\$1,925
4	\$367	\$733	\$1,100	\$1,467	\$1,834	\$2,200	\$2,567
Level II: Master's + 30 Credit Hours							
		Rate:		\$614			
Compensation = Rate [1/7(No. of Credits x No. of Students)]							
Credits	1 Student	2 Students	3 Students	4 Students	5 Students	6 Students	7 Students
1	\$100	\$175	\$263	\$351	\$438	\$526	\$614
2	\$175	\$351	\$526	\$701	\$877	\$1,052	\$1,228
3	\$263	\$526	\$789	\$1,052	\$1,315	\$1,578	\$1,841
4	\$351	\$701	\$1,052	\$1,403	\$1,754	\$2,104	\$2,455
Level III: Master's / Highly Technical							
		Rate:		\$584			
Compensation = Rate [1/7(No. of Credits x No. of Students)]							
Credits	1 Student	2 Students	3 Students	4 Students	5 Students	6 Students	7 Students
1	\$100	\$167	\$250	\$334	\$417	\$500	\$584
2	\$167	\$334	\$500	\$667	\$834	\$1,001	\$1,168
3	\$250	\$500	\$751	\$1,001	\$1,251	\$1,501	\$1,751
4	\$334	\$667	\$1,001	\$1,334	\$1,668	\$2,001	\$2,335
Level IV: Bachelor's							
		Rate:		\$535			
Compensation = Rate [1/7(No. of Credits x No. of Students)]							
Credits	1 Student	2 Students	3 Students	4 Students	5 Students	6 Students	7 Students
1	\$100	\$153	\$229	\$306	\$382	\$458	\$535
2	\$153	\$306	\$458	\$611	\$764	\$917	\$1,070
3	\$229	\$458	\$688	\$917	\$1,146	\$1,375	\$1,604
4	\$306	\$611	\$917	\$1,222	\$1,528	\$1,834	\$2,139

Level V: Associate's Degree / Assistant Instructor							
		Rate:	\$505				
Compensation = Rate [1/7(No. of Credits x No. of Students)]							
Credits	1 Student	2 Students	3 Students	4 Students	5 Students	6 Students	7 Students
1	\$100	\$144	\$216	\$288	\$361	\$433	\$505
2	\$144	\$288	\$433	\$577	\$721	\$865	\$1,010
3	\$216	\$433	\$649	\$865	\$1,082	\$1,298	\$1,514
4	\$288	\$577	\$865	\$1,154	\$1,442	\$1,731	\$2,019

Any qualified instructor, whether full-time or part-time, may teach independent study courses. For full-time faculty members who teach an independent study, but do not have a full load for a specified term, the independent study will be considered part of their regular instructional load duties, and no additional compensation will be given. Any instructor teaching an independent study for a class they are currently already teaching will only receive compensation for that independent study if the class size is equal to or greater than the state standardized class size. For classes that do not have the minimum enrollment, instructors may be compensated at a reduced rate in accordance with the independent study compensation schedule.

ONLINE LEARNING COURSE INSTRUCTION

Compensation for online courses is based on course credit load. Online courses taught by an Adjunct is paid using the Adjunct Salary Schedule. Level of compensation is based on the highest degree(s) held by the instructor or the level the instructor is credentialed to teach. For load purposes a standard course is three credits.

ONLINE COURSE DEVELOPMENT COMPENSATION

Compensation for online course development is \$500 per course, with prior written approval by the Vice President, Academic Affairs, and compensation will be paid upon approval and completion of the course as prescribed in the Online Course Development Standards.

RELEASE TIME

At the President's discretion, release time may be provided to full-time faculty members who serve as standing committee chairpersons when the College documents a significant workload increase due to chairperson responsibilities.

FACULTY TITLES

Faculty titles include Instructors, Assistant Professors, Associate Professors, and Professors. Faculty titles are determined by consideration of the faculty member's teaching experience and education, as detailed on the next page.

Faculty Title Chart					
Teaching Experience:	Education Achieved:				
	Level I: Doctrate	Level II: Master's Degree + 30 related credits	Level III: Master's Degree	Level IV: Bachelor's Degree	Level V: Associate's Degree
Years					
1	Instructor	Instructor	Instructor	Instructor	Instructor
2	Instructor	Instructor	Instructor	Instructor	Instructor
3	Instructor	Instructor	Instructor	Instructor	Instructor
4	Assistant Professor	Assistant Professor	Assistant Professor	Assistant Professor	Assistant Professor
5	Assistant Professor	Assistant Professor	Assistant Professor	Assistant Professor	Assistant Professor
6	Assistant Professor	Assistant Professor	Assistant Professor	Assistant Professor	Assistant Professor
7	Assistant Professor	Assistant Professor	Assistant Professor	Assistant Professor	Assistant Professor
8	Associate Professor	Assistant Professor	Assistant Professor	Assistant Professor	Assistant Professor
9	Associate Professor	Assistant Professor	Assistant Professor	Assistant Professor	Assistant Professor
10	Associate Professor	Associate Professor	Assistant Professor	Assistant Professor	Assistant Professor
11	Associate Professor	Associate Professor	Associate Professor	Assistant Professor	Assistant Professor
12	Associate Professor	Associate Professor	Associate Professor	Associate Professor	Assistant Professor
13	Associate Professor	Associate Professor	Associate Professor	Associate Professor	Associate Professor
14	Professor	Associate Professor	Associate Professor	Associate Professor	Associate Professor
15	Professor	Associate Professor	Associate Professor	Associate Professor	Associate Professor
16	Professor	Professor	Associate Professor	Associate Professor	Associate Professor
17	Professor	Professor	Associate Professor	Associate Professor	Associate Professor
18	Professor	Professor	Associate Professor	Associate Professor	Associate Professor
19	Professor	Professor	Associate Professor	Associate Professor	Associate Professor
20	Professor	Professor	Professor	Associate Professor	Associate Professor
21	Professor	Professor	Professor	Associate Professor	Associate Professor
22	Professor	Professor	Professor	Professor	Associate Professor
23	Professor	Professor	Professor	Professor	Associate Professor
24	Professor	Professor	Professor	Professor	Professor

ADJUNCT AND OVERLOAD COMPENSATION

ADJUNCT AND OVERLOAD COMPENSATION

Adjunct Instructors are allowed to teach a maximum of nine credit hours per term. Adjunct and overload compensation is paid semi-monthly according to the annual Payroll Schedule, which is available on the J: drive, under Human Resources and in Banner Self-Service under Employee Self-Service, Pay Information.

ADJUNCT, OVERLOAD, AND SUBSTITUTE INSTRUCTOR COMPENSATION^{1,2}

LEVEL	DEGREE	RATE	Classroom Contact Hour Rate*
I	Doctorate	\$642 per credit hour	\$42.80 per hour
II	Master's + 30 credit hours	\$614 per credit hour	\$40.93 per hour
III	Master's/Highly Technical ³	\$584 per credit hour	\$38.93 per hour
IV	Bachelor's	\$535 per credit hour	\$35.69 per hour
V	Associate Degree/ Asst. Instructor	\$505 per credit hour	\$33.66 per hour

*15 Classroom contact hours per credit. Part-time Instructor rate. Any increases to adjunct pay rates are effective on faculty's first duty day for the fall term.

ADJUNCT PERFORMANCE EVALUATIONS

Adjunct instructors will be evaluated on performance at the end of their first term and then annually, thereafter.

SENIOR ADJUNCT FACULTY

An Adjunct Instructor who completes five academic years of continuous service teaching, at least, two courses per academic year and whose instructional evaluations, classroom observation, and student evaluations have received a score of "satisfactory" or higher, will be recognized as a Senior Adjunct Faculty member and is eligible for a 10% increase above the normal Adjunct pay rate.

PROFESSIONAL DUTY COMPENSATION

Professional duty compensation is \$17.50/hour⁴. This may be paid as a supplement to full-time and part-time, regular and temporary College employees, and to Adjunct instructors who work on a finished product such as a report, project, consulting services, or other "hourly duty" responsibilities. Time sheets are required to document hours worked.

¹A reduced rate may be paid for class size of less than seven students, subject to the approval of the President.

²Two laboratory hours equate to one credit hour for payment purposes unless special conditions allow for a different ratio. The President or designee may approve deviation from this ratio.

³Instructors who teach highly technical vocational programs require a high degree of professional skill and experience in the field.

⁴Hourly rate of compensation may vary depending on the services, and when recommended by TADA and approved by the President, the rate may be in excess of \$17.50 per hour.

CAREER

CAREER

EMPLOYMENT AUTHORIZATION

Full-time, part-time and temporary Career employees are placed at the appropriate grade and range for their positions. The President is authorized by the Board of Trustees to employ part-time and temporary Career employees. The Board of Trustees must approve full-time employment.

NON-EXEMPT STATUS, OVERTIME ELIGIBILITY

Non-exempt Career employees are paid overtime or receive compensatory time for work performed over forty (40) hours per week. This includes total hours worked for course preparation time. Payment of overtime or compensatory time is made in accordance with the Fair Labor Standards Act. Overtime provisions for College employees are reflected in College Procedure No. 52.4. Except in extraordinary circumstances approved in advance by the President, non-exempt Career employees are not authorized to work more than forty (40) hours in any work week. Record-keeping procedures for hours worked by non-exempt employees are provided in College Procedure No. 56.53.

PART-TIME CAREER POSITIONS

The standard work schedule for part-time Career employees is twenty-five (25) hours per week or less. Individual work schedules are determined by the supervisor. Schedules may vary on a week-to-week basis depending on the needs of the department. Except in extraordinary circumstances approved in advance by the President, part time Career employees are not authorized to work more than twenty-five (25) hours in any work week.

Part-time Career positions are placed in the appropriate pay grade for the position at the time of appointment. Appointment of part-time Career employees is recommended by the President and approved by the Board of Trustees. Pay is determined by the grade in which the position has been classified and is typically set at the minimum pay level for the position. Exceptions may be made for education and experience above that of the required qualifications with the President's approval.

EMPLOYEE EVALUATIONS

Probationary Evaluation

Full-time, part-time, and temporary employees are under a probationary period for the first six months of employment. During this probationary period employment is "at will", meaning that the employee may be discharged by the College, or may choose to leave the College, without cause. Their immediate supervisor evaluates job performance at the end of this probationary period and recommends to the Executive/Administrative supervisor: 1) removal from probation and continuation of employment; 2) extension of the probation period for up to an additional 90 days; or 3) termination of employment. The probationary period may not extend beyond a total of nine months. Current employees who transfer to another position are not subject to an additional probationary review. However, it is expected that supervisors will monitor job performance and communicate regularly with employees regarding performance and expectations.

Annual Evaluations

Career employees participate in an annual evaluation with their immediate supervisor in or around the month of April of each fiscal year.

CAREER OVERTIME PROCEDURES FOR EMPLOYEES WHO PERFORM OVER TIME AT TWO OR MORE JOBS AT DIFFERENT RATES OF PAY

With the President's prior approval, non-exempt employees who work more than forty (40) hours per week are due overtime payment or compensatory time. The method of overtime calculation for multiple jobs at different hourly rates of pay is based on a weighted average rate of employee compensation.

Step 1: $\text{Gross Wages} / \text{All hours worked} = \text{Weighted Average Rate}$

Step 2: $\text{Weighted Average Rate} \times 1.5 \times \text{Total Hours Worked over 40 hrs. per week} = \text{Total Overtime Pay}$

Example: An employee works 37.5 hours per week in a regularly established position making \$10.00 per hour. The employee then works ten hours a week in a grant funded position making \$12.00 per hour. The employee is working 7.5 overtime hours. Payment calculation is as follows:

$$\begin{aligned} \$375.00 + \$120.00 &= \$495 \text{ gross wages} / 47.5 \text{ total hours worked} = \$10.42 \text{ (Weighted Average Rate)} \\ \$10.42 \times 1.5 &= \$15.63 * 7.5 \text{ hours of overtime} = \$117.23 \text{ (Total Overtime Pay)} \\ \$117.23 \text{ overtime pay} + \\ \$495.00 \text{ gross wages} &= \$612.23 \text{ (Total Pay)} \end{aligned}$$

CAREER 2022-2023 SALARY SCHEDULE*

Grade	Position Title	Hourly Range
3	Enrollment Services Specialist Maintenance Specialist Manager, Dive Facilities Program Specialist Science Laboratory Technician Specialist, Academic Support Services	\$18.59 - \$30.97
2	Administrative Assistant, Community Engagement & Testing Administrative Assistant, Institute for Public Safety	\$15.93 - \$26.55
1	Aquatics Personnel (PT) Clerical Assistant (PT) Laboratory Assistant, Biology/Chemistry (PT) Laboratory Assistant, Marine Eng., Marine Sciences, Computer Science, Culinary, Nursing (PT)	\$15.00 - \$24.57

*NOTICE: Salary Range does not reflect the available starting salaries, which are limited to 10.0% above the minimum salary, per the Starting Salary Determination in this Salary Schedule. Salary Ranges may be adjusted further to reflect pay equity, or market demands, contingent upon budget constraints and the approval of the Director of TADA and the President.

MISCELLANEOUS EMPLOYMENT

MISCELLANEOUS EMPLOYMENT

EMPLOYMENT OF DAY LABOR AND PERSONNEL SERVICE CONTRACTS

Individuals employed on day labor projects, or employed to perform services requiring special skills, training or experience, on a part-time or temporary basis, are paid at no less than the current minimum wage. Actual wages are determined according to the skills, training or experience required.

OTHER EMPLOYMENT

Employment of Student Assistants, Student Work Study, and Artist's Models is approved by the President or designee and does not require Board of Trustees' Action.

- A. Student Assistants: paid at the minimum range of a similar type of position on the Career Salary Schedule. TADA compensation recommendations are based on experience, qualifications, and skills required of the position.
- B. Artist's Models: \$15.00/hour.
- C. College Work Study Students: \$15/hour. There will be a \$0.50 increase each fall and spring term for returning work study students. Hourly rate not to exceed \$17.00. All programs (Florida Work Experience Program [FWEP], Perkins Grant, and College Work Study) and rates are dependent on Financial Aid funding.
- D. Student Accessibility Services: \$15.00 to \$35.00/hour, depending on level of specialization.
- E. Tutor / Note Taker: \$15.00/hour.
- F. Technical Advisors (Diving, Engineering Technology, Marine Science, and STEM): \$17.50 /hour. \$25.00 /hour if supported by a grant or contract such as the Army Corp of Engineers.
- G. Paid Internships: minimum wage - \$17.50 per hour
- H. Boat Captains: \$25.00 per hour
- I. Deck Hands: \$17.50 per hour
- J. Summer Camp Personnel:

Director	\$22.50/hour
Instructor	\$20.00/hour
Assistant	\$15.00/hour

SUPPLEMENTAL PAY FOR STUDENT CLUB ADVISORS

Student clubs are chartered in the fall and spring terms. Unless otherwise part of their normal duties, Club Advisors may be paid a stipend each term. Payment is made at the end of the term upon satisfactory completion of Club Advisor requirements, as per the Club Advisor Agreement on file with the Office of Student Activities.

EMPLOYEE CATEGORIES
COLLEGE PAID FRINGE BENEFITS

EMPLOYEE CATEGORIES AND COLLEGE-PAID FRINGE BENEFITS

EMPLOYEE CATEGORIES

- A. Full-time: Executive, Administrative, Professional, Career, and Instructional Faculty employment requires a minimum of 37.5 regularly scheduled hours per week.
- B. Part-time: Positions requiring 25 hours per week or less.
- C. Temporary Position: Employment not to exceed six consecutive months.
- D. Regularly Established, Non-Instructional Position: Grant funded employment exceeding six consecutive months or total intermittent employment exceeding 2,080 hours.

ELIGIBILITY FOR FRINGE BENEFITS PAID BY THE COLLEGE BASED ON EMPLOYEE CATEGORY

- A. Full-time, Regularly Established Position - 7.65% of compensation for Social Security/Medicare; 10.82% contribution to the Florida Retirement System*; paid health insurance coverage for employee; \$.15 per each thousand dollars of compensation (to a maximum of \$50,000) per month for Basic Active Life Insurance and Accidental Death and Dismemberment (AD&D); employee assistance program; and 403b plan.
- B. Part-time, Regularly Established Position- 7.65% of compensation for Social Security/Medicare; 10.82% contribution to the Florida Retirement System*; and 403b plan.
- C. Full-time, Temporary Position - 7.65% of compensation for Social Security/Medicare and 403b plan.
- D. Part-time, Temporary Position - 7.65% of compensation for Social Security/Medicare and 403b plan.
- E. Designated Senior Management Service Class Position – 7.65% of compensation for Social Security/Medicare; 29.01% contribution to the Florida Retirement System*; paid health insurance coverage for employee; \$.15 per each thousand dollars of compensation (to a maximum of \$50,000) per month for Basic Active Life Insurance and AD&D; employee assistance program; and 403b plan.

*Employees are required to pay 3% of gross pay into their Florida Retirement System plan. Rates listed above are the entire amount paid per employee, inclusive of 1.66% HIS Contribution rate, 0.06% administrative/educational fee and applicable Unfunded Actuarial Liability (UAL) rates. Additional information regarding FRS rates can be found here: https://www.dms.myflorida.com/workforce_operations/retirement/employers/contribution_rates

Retirees from The College of the Florida Keys are allowed to continue to purchase health, dental, vision, and life insurance through the College's provider for themselves and their eligible dependents.

APPENDIX A
ORGANIZATIONAL CHARTS

The College of the Florida Keys 2022/2023 Organizational Chart
District Board of Trustees

District Board of Trustees

- Stephanie Scuderi, Chair
- Kevin Madok, Vice Chair
- Sheldon Suga, Trustee
- Elena Spottswood, Trustee
- Mike Puto, Trustee

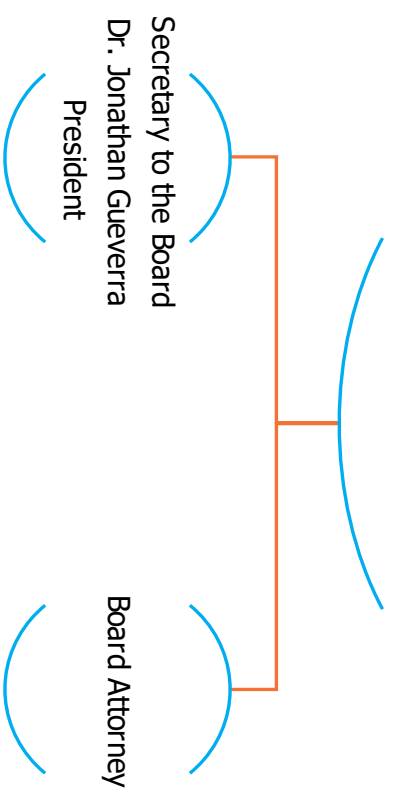

The College of the Florida Keys 2022/2023 Organizational Chart
Executive Leadership

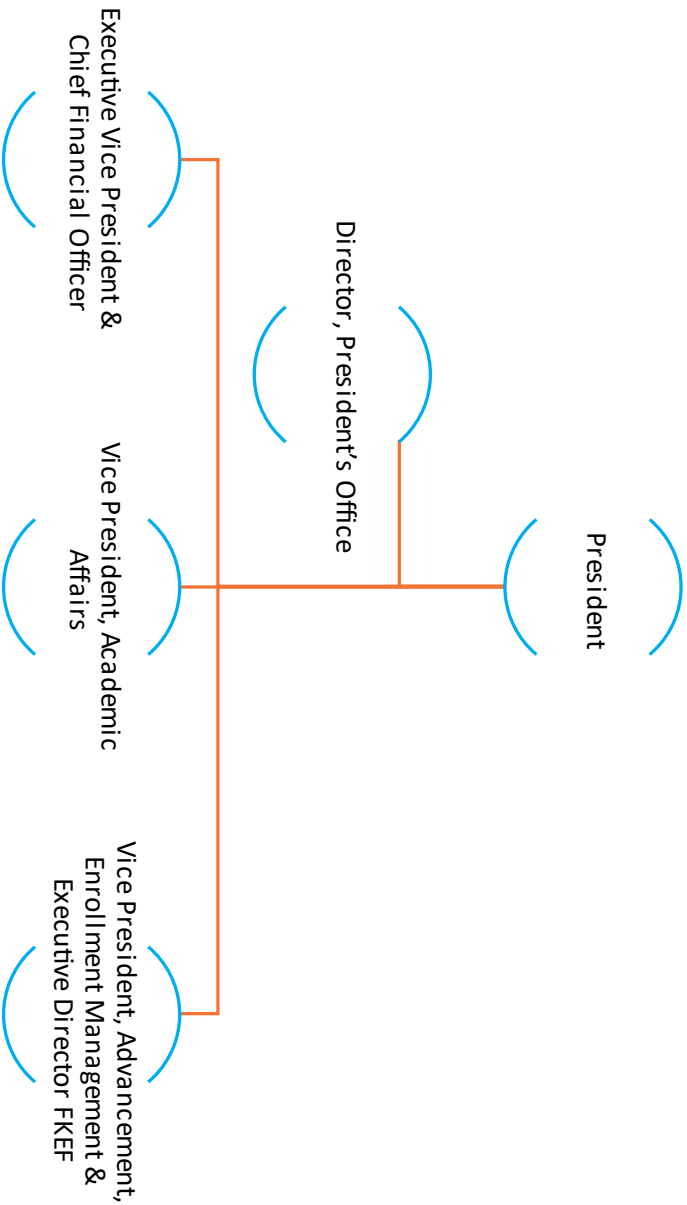

The College of the Florida Keys 2022-2023 Organizational Chart Academic Affairs

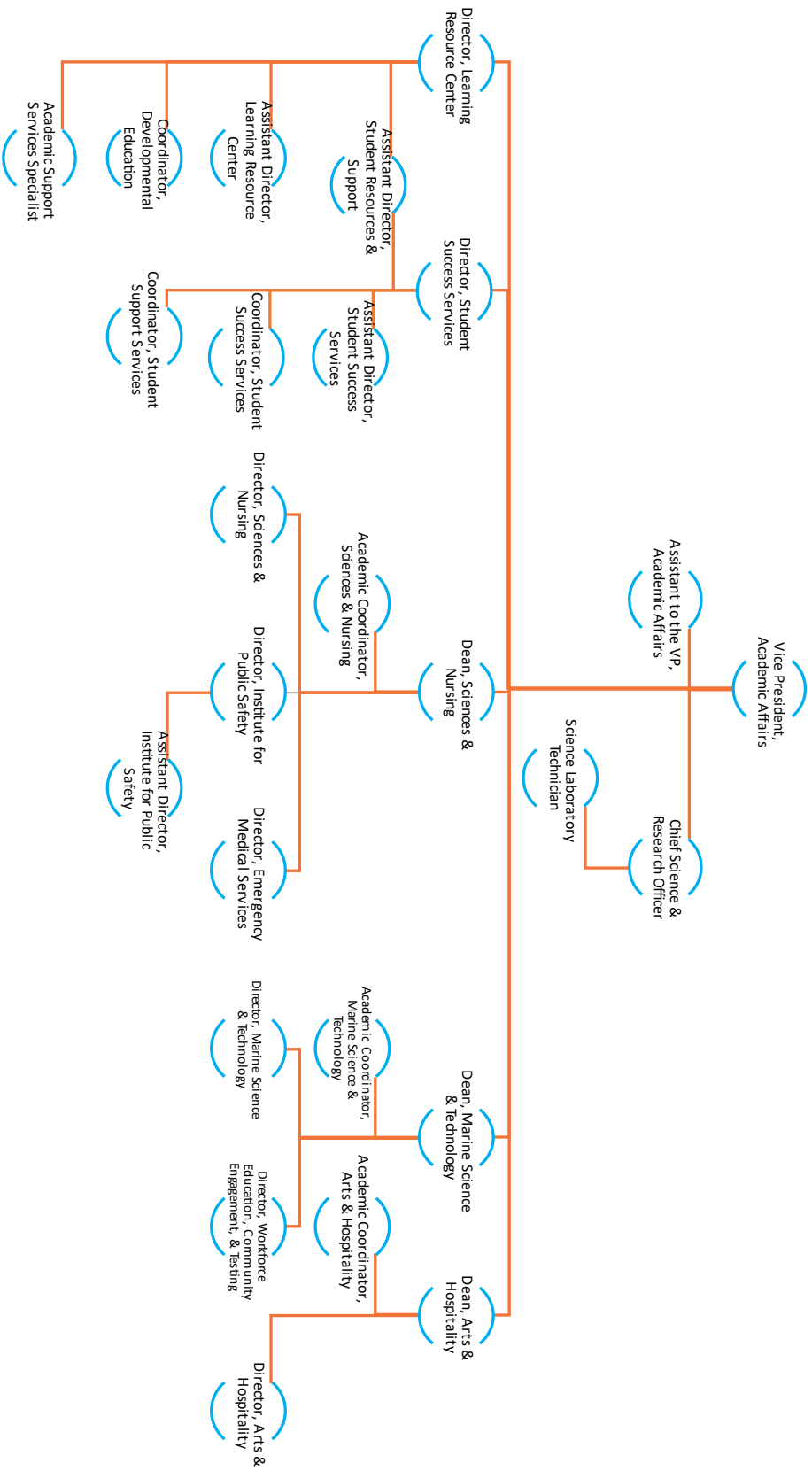

The College of the Florida Keys 2022/2023 Organizational Chart Finance & Administration

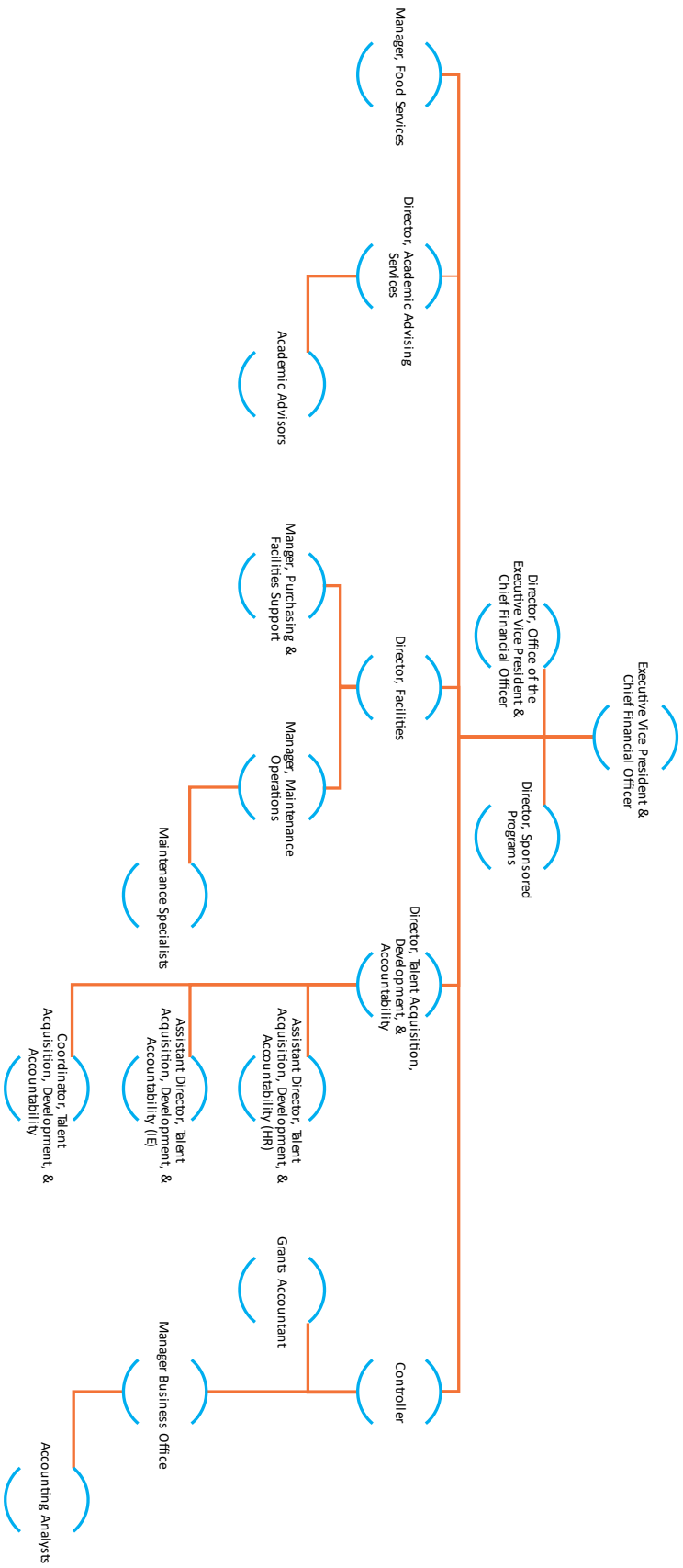

**The College of the Florida Keys 2022/2023 Organizational Chart
 Advancement, Enrollment Management & Florida Keys Education Foundation**

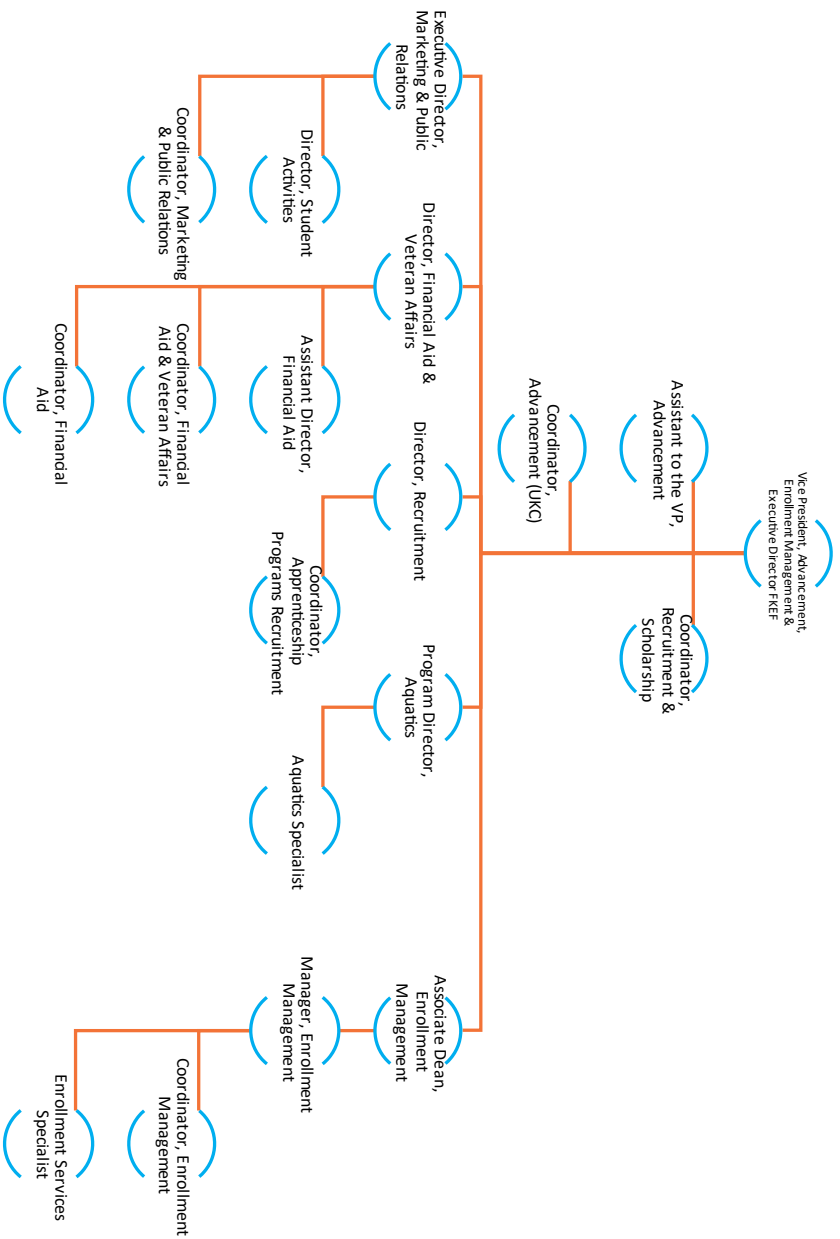

The College of the Florida Keys 20222023 Organizational Chart
 Instructional Division: Arts & Hospitality

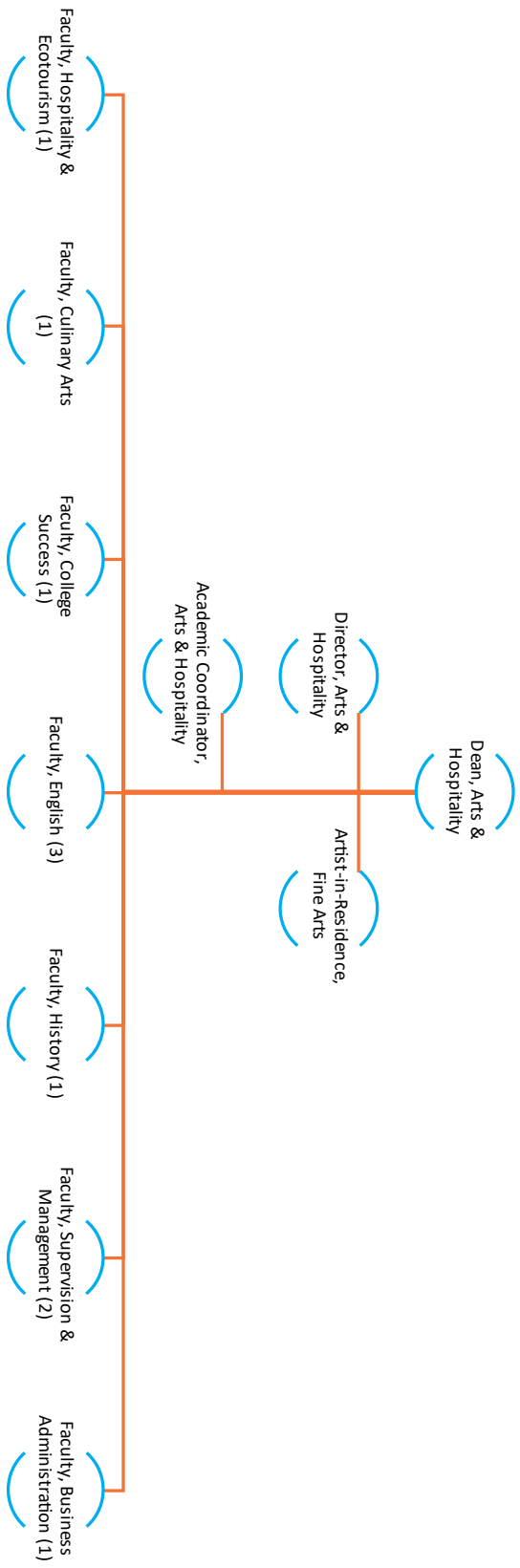

The College of the Florida Keys 20222023 Organizational Chart
Instructional Division: Sciences & Nursing

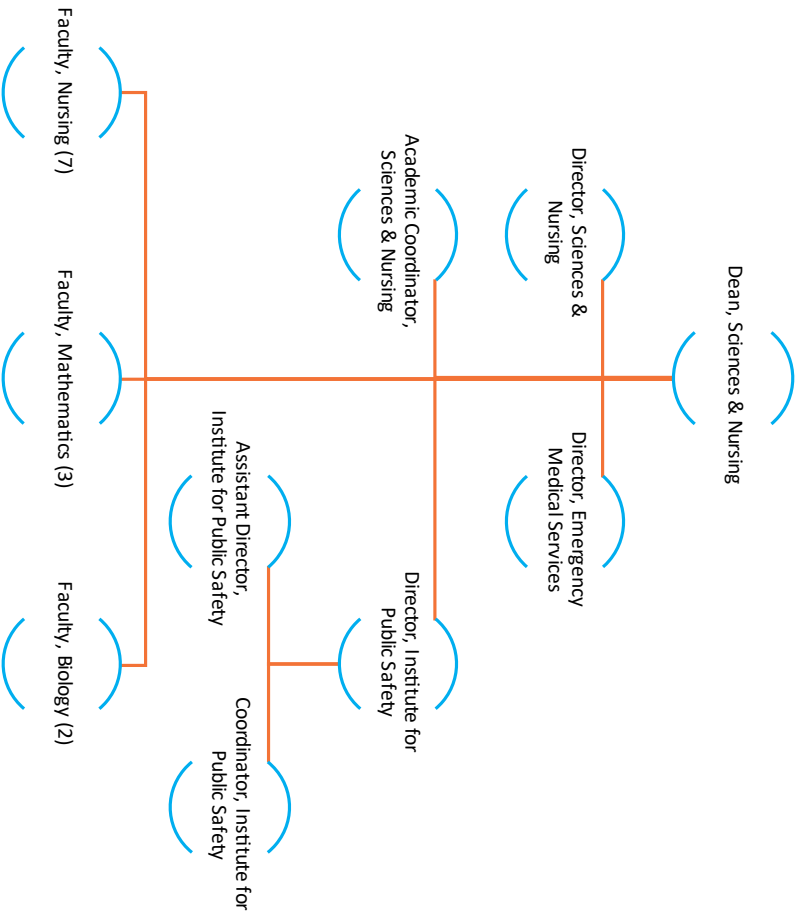

The College of the Florida Keys 2022/2023 Organizational Chart Instructional Division: Marine Science & Technology

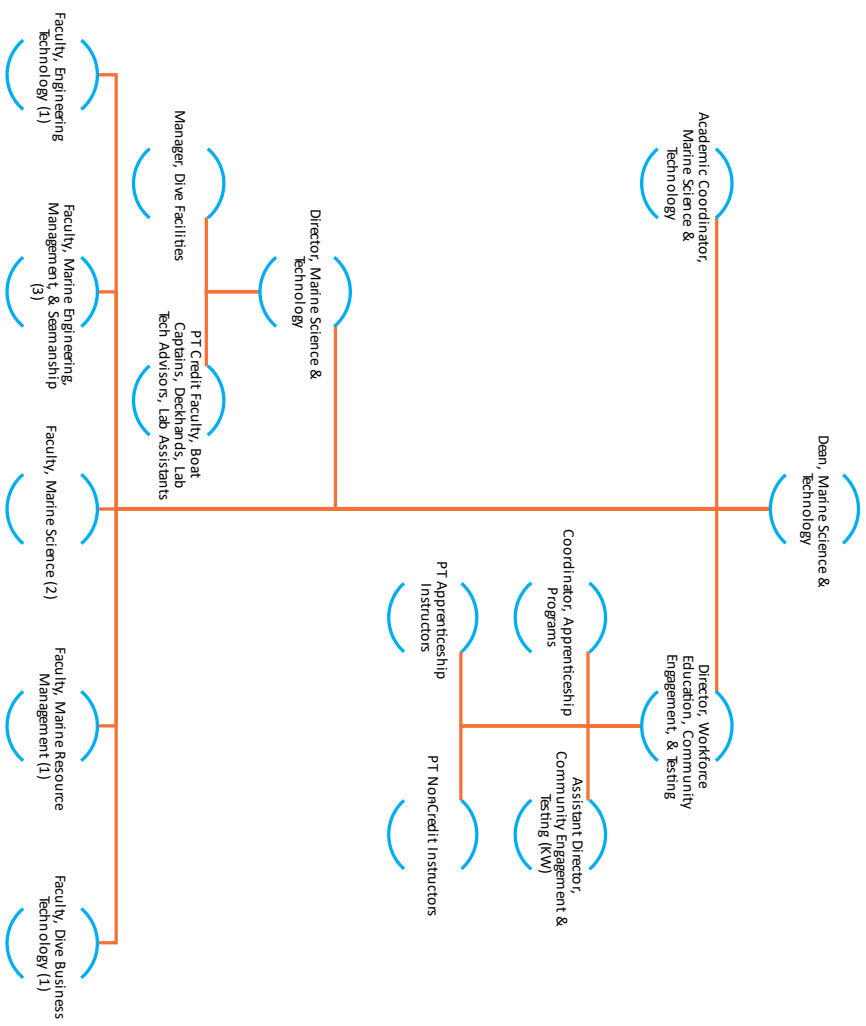



THE COLLEGE OF THE FLORIDA KEYS

PRESIDENT/CEO:

Dr. Jonathan Gueverra

BOARD OF TRUSTEES:

Stephanie Scuderi, Chair
Kevin Madok, Vice-Chair
Mike Puto, Trustee
Elena Spottswood, Trustee
Sheldon Suga, Trustee

MISSION:

The College of the Florida Keys is an open access, educational institution dedicated to serving the intellectual, diverse, cultural, and occupational needs of the Florida Keys as well as the global community. The College is committed to student-centric academic programs and services, workforce development, continuing education, diverse partnerships, electronically delivered instruction, and sustainable practices that prepare students for personal success and responsible citizenship.

STATEMENT OF ACCREDITATION:

The College of the Florida Keys is accredited by the Southern Association of Colleges and Schools Commission on Colleges (SACSCOC) to award associate and baccalaureate degrees. Questions about the accreditation of The College of the Florida Keys may be directed in writing to the Southern Association of Colleges and Schools Commission on Colleges at 1866 Southern Lane, Decatur, GA 30033-4097, by calling (404) 679-4500, or by using information available on SACSCOC's website (www.sacscoc.org).

NOTICE OF NON-DISCRIMINATION:

The College of the Florida Keys does not discriminate on the basis of race, color, national origin, ethnicity, age, sex (including sexual orientation and gender identity), marital status, military status, protected veteran status, genetic information, religion, pregnancy, or disability in its programs, activities, or employment practices. The following persons have been designated to handle inquiries and grievances regarding the non-discrimination policies:

Equity Officer: Jose Reyes, Assistant Director, Talent Acquisition, Development and Accountability
(305) 809-3163 or jose.reyes1@cfk.edu

Title IX Coordinator: Naomi Walsh, Assistant to VP of Advancement
(305) 809-3198 or naomi.walsh@cfk.edu

Disability Services: Katie Norland, Director of Student Success
(305) 809-3181 or katie.norland@cfk.edu

Mailing Address:

The College of the Florida Keys
5901 College Road, Key West, FL 33040